

WELDED STEEL PIPES PIPE NIPPLES

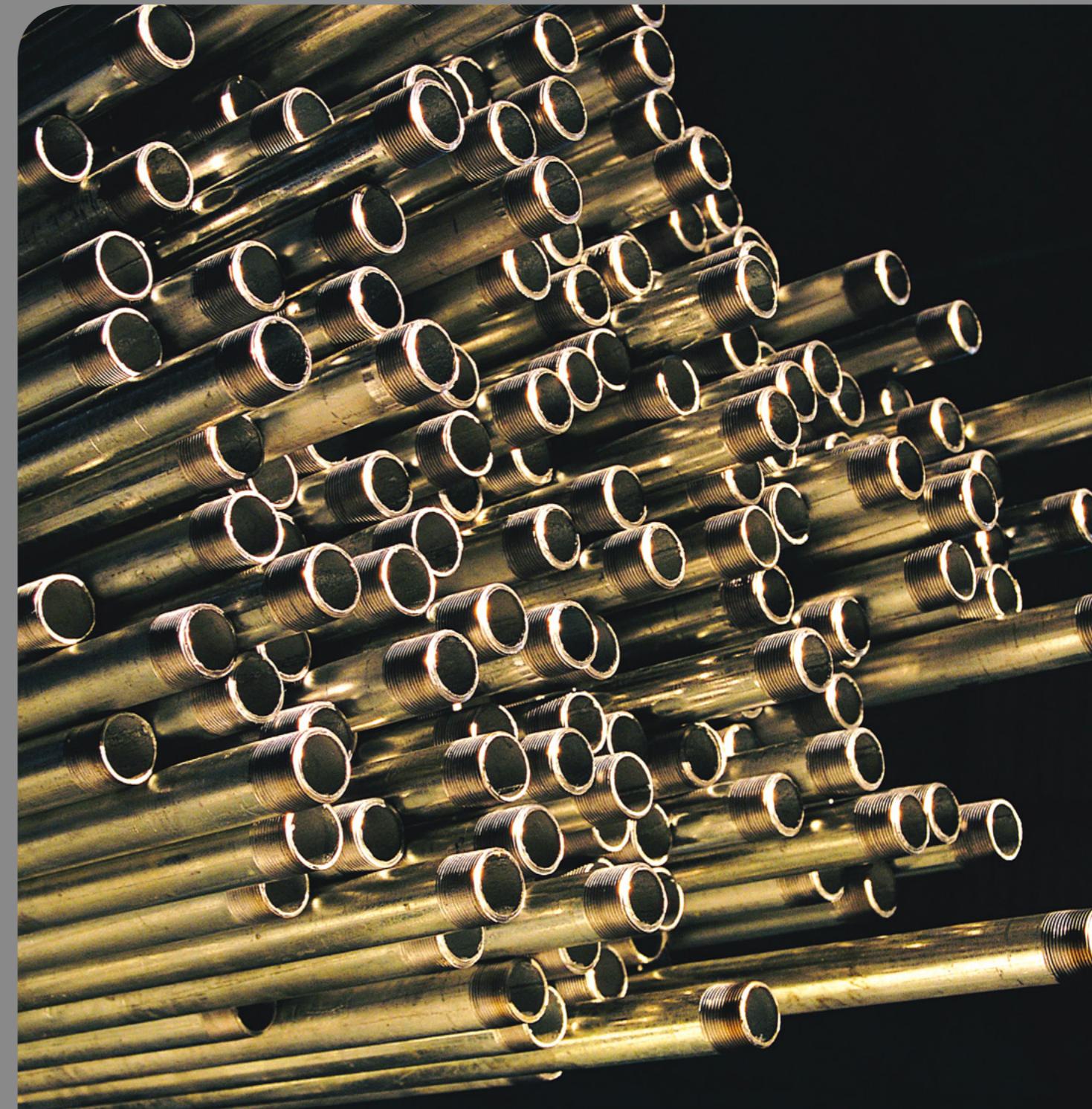

JINAN MECH PIPING TECHNOLOGY CO., LTD.

MECH FLOW SUPPLIES

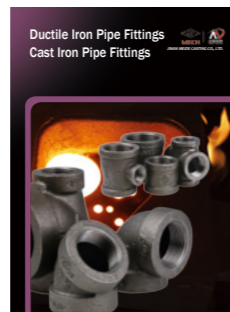
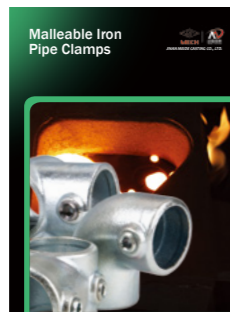
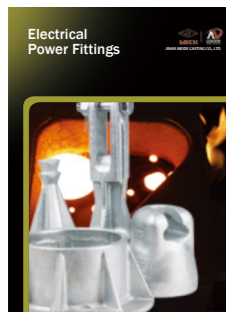

MECH

JINAN MECH PIPING TECHNOLOGY CO., LTD.

Address: Meigui Zone of Industrial Park, Pingyin, Jinan, China

Tel : (86)531 87856140 87601888

Fax: (86)531 87879387 87666796

Email: carol.liu@meide-casting.com

Http://www.meide-casting.com

UPDATED 01/2017

Company Profile

Jinan Mech Piping Technology Co., LTD was established in 2013, which is specialized on manufacturing welded steel pipes, pipe nipples and spiral pipes. It has 1 factory of welded steel pipes, 1 factory of steel nipples and 1 for spiral pipes.

The company invested many sets of advanced automatic production lines, including 5 welding lines of 15, 20, 50, 140, 219, 1 hot-dip galvanizing line, 2 plastic lining line, 2 painting lines, 1 epoxy line, many sets of threaded machines and grooved machines. The company produces all kinds of pipes including Black welded steel pipes, Hot-dip galvanized Steel pipes, Painted steel pipes, Plastic lining pipes, PE coated steel pipes and steel pipe nipples, which comply with domestic and international standards

of ASTM A53, ASTM A795, BS 1387, EN 10255, AS 1074, SANS 62, GB/T 3091-2008, GB/T14291、CJ/T 120-2008、CJ/T 136-2007. The pipes we produced are under diameter from 1/2" to 8". All these pipes are used widely in the industries of water, gas, mining, fire protection, oil and other related fields.

The company organizes the whole production process in accordance with ISO 9001, and gets the approval of API 5L/UL/FM/NSF of US, TUV of Germany, SII of Israel etc. The products are well distributed in more than 50 countries and regions.

Customer satisfaction has always been the company's top objective, and we constantly stick to the principle: to provide customers with a value-added solution rather than simply delivering products.



Advanced Equipment

High precision equipment is quality assurance.
 Jinan Mech Piping Technology Co., Ltd is equipped with the most advanced facilities and equipment in the industry. The main equipment include: automatic welding line, hot-dip galvanizing line, painting line, epoxy coating line, grooved machine and threaded machine and so on.



Welding Line



Hot-dip Galv. line



Painted Line



Plastic-Lining Line



Epoxy Line



PE Pipe Line



Welding Machine

Reliable Quality Assurance

Quality is checked and monitored in the whole process from incoming inspection to finished production inspection. Each step of the manufacturing process is carefully documented, regularly reviewed for revision control and updating standard. Quality procedures are constantly monitored and updated to assure that only the highest and most consistent quality products are supplied to our valued customers.

Inspection facilities include: Spectral Analysis Machine, Metallographic Testing Machine, Universal Material Testing Machine, Eddy Current testing Machine, Hydraulic Testing Machine, Impact Testing Machine, etc.



Hydraulic Testing Machine



Annealing



Eddy Current Testing Machine



Tensile Strength Testing Machine



Spectrometer

Certificates



济南市国产涉及饮用水卫生安全产品卫生许可条件

产品名称	双克牌饮用水用内衬环氧玻璃钢复合钢管
产品类别	输配水设备
产品规格型号	DN150mm-DN250mm
申报单位	济南迈克管道科技股份有限公司
申报单位地址	山东平阴工业园区玫瑰片区
实际生产企业	济南迈克管道科技股份有限公司
实际生产企业地址	山东平阴工业园区玫瑰片区
审批结论	经审查,该产品符合《生活饮用水卫生监督管理办法》的有关规定,准予批准。
批准文号	鲁卫生字【2016】第4813号
批准日期	2016年04月01日
批准有效期	截至2020年03月31日

济南市国产涉及饮用水卫生安全产品卫生许可条件

产品名称	双克牌饮用水用内衬环氧玻璃钢复合钢管
产品类别	输配水设备
产品规格型号	DN150mm-DN250mm
申报单位	济南迈克管道科技股份有限公司
申报单位地址	山东平阴工业园区玫瑰片区
实际生产企业	济南迈克管道科技股份有限公司
实际生产企业地址	山东平阴工业园区玫瑰片区
审批结论	经审查,该产品符合《生活饮用水卫生监督管理办法》的有关规定,准予批准。
批准文号	鲁卫生字【2016】第4813号
批准日期	2016年04月01日
批准有效期	截至2020年03月31日

共2页 第2页

【产品说明】	该产品为双克牌,符合《生活饮用水卫生监督管理办法》的有关规定,准予批准。
【产品规格】	DN150mm-DN250mm
【产品性能】	该产品为双克牌,符合《生活饮用水卫生监督管理办法》的有关规定,准予批准。
【产品用途】	该产品为双克牌,符合《生活饮用水卫生监督管理办法》的有关规定,准予批准。
【产品材料】	该产品为双克牌,符合《生活饮用水卫生监督管理办法》的有关规定,准予批准。
【产品标准】	该产品为双克牌,符合《生活饮用水卫生监督管理办法》的有关规定,准予批准。
【产品检验】	该产品为双克牌,符合《生活饮用水卫生监督管理办法》的有关规定,准予批准。
【产品认证】	该产品为双克牌,符合《生活饮用水卫生监督管理办法》的有关规定,准予批准。
【产品备注】	该产品为双克牌,符合《生活饮用水卫生监督管理办法》的有关规定,准予批准。

共2页 第2页

【产品说明】	该产品为双克牌,符合《生活饮用水卫生监督管理办法》的有关规定,准予批准。
【产品规格】	DN150mm-DN250mm
【产品性能】	该产品为双克牌,符合《生活饮用水卫生监督管理办法》的有关规定,准予批准。
【产品用途】	该产品为双克牌,符合《生活饮用水卫生监督管理办法》的有关规定,准予批准。
【产品材料】	该产品为双克牌,符合《生活饮用水卫生监督管理办法》的有关规定,准予批准。
【产品标准】	该产品为双克牌,符合《生活饮用水卫生监督管理办法》的有关规定,准予批准。
【产品检验】	该产品为双克牌,符合《生活饮用水卫生监督管理办法》的有关规定,准予批准。
【产品认证】	该产品为双克牌,符合《生活饮用水卫生监督管理办法》的有关规定,准予批准。
【产品备注】	该产品为双克牌,符合《生活饮用水卫生监督管理办法》的有关规定,准予批准。



Specifications of Welded & Seamless Steel

ASTM A795 Standard Specification for Black and Hot-Dipped Galvanized Welded and seamless steel pipe for fire Protection Use

Schedule	Nominal Size	Outside Diameter	Wall Thickness	Mass of Black Tube	Test Pressure
	(inch)	(mm)	(mm)	Plain End (kg/m)	Grade B (PSI)
Schedule 10	3/4"	26.7	2.11	1.28	700
	1"	33.4	2.77	2.09	700
	1 1/4"	42.2	2.77	2.69	1000
	1 1/2"	48.3	2.77	3.11	1000
	2"	60.3	2.77	3.93	1000
	2 1/2"	73.0	3.05	5.26	1000
	3"	88.9	3.05	6.46	1000
	4"	114.3	3.05	8.37	1200
	5"	141.3	3.40	11.58	1200
	6"	168.3	3.40	13.85	1000
	8"	219.1	4.78	25.26	800
	10"	273	4.78	31.62	700
	Schedule 40	1/2"	21.3	2.77	1.27
3/4"		26.7	2.87	1.69	700
1"		33.4	3.38	2.5	700
1 1/4"		42.2	3.56	3.39	1300
1 1/2"		48.3	3.68	4.05	1300
2"		60.3	3.91	5.44	2500
2 1/2"		73.0	5.16	8.63	2500
3"		88.9	5.49	11.29	2500
4"		114.3	6.02	16.07	2210
5"		141.3	6.55	21.77	1950
6"		168.3	7.11	28.26	1780
8"		219.1	8.18	42.55	1570
10"		273	9.27	60.29	1430

Note: Wall thickness tolerance is -12.5%
Length tolerance is +20mm/0

ASTM A53 Standard Specification for Pipe, Steel, Black and Hot-Dipped, Welded and Seamless

Schedule	Nominal Size	Outside Diameter	Wall Thickness	Mass of Black Tube	Test Pressure
	(inch)	(mm)	(mm)	Plain End (kg/m)	Grade B (PSI)
Schedule 40	1/2"	21.3	2.77	1.27	700
	3/4"	26.7	2.87	1.69	700
	1"	33.4	3.38	2.5	700
	1 1/4"	42.2	3.56	3.39	1300
	1 1/2"	48.3	3.68	4.05	1300
	2"	60.3	3.91	5.44	2500
	2 1/2"	73	5.16	8.63	2500
	3"	88.9	5.49	11.29	2500
	4"	114.3	6.02	16.07	2210
	5"	141.3	6.55	21.77	1950
	6"	168.3	7.11	28.26	1780
	8"	219.1	8.18	42.55	1570
	10"	273	9.27	60.29	1430
Schedule 80	1/2"	21.3	3.73	1.62	850
	3/4"	26.7	3.91	2.2	850
	1"	33.4	4.55	3.24	850
	1 1/4"	42.2	4.85	4.47	1900
	1 1/2"	48.3	5.08	5.41	1900
	2"	60.3	5.54	7.48	2500
	2 1/2"	73	7.01	11.41	2500
	3"	88.9	7.62	15.27	2500
	4"	114.3	8.08	22.32	2800
	5"	141.3	8.56	30.94	2800
	6"	168.3	10.97	42.56	2740
	8"	219.1	12.7	64.64	2430
	10"	273	15.09	95.97	2320
12"	323.8	17.48	132.04	2270	

Note: Wall thickness tolerance is -12.5%
Length tolerance is +20mm/0

Specifications of Welded Steel Pipe

BS 1387 Specification for Screwed and Socketed Steel Tubes and Tubulars and for Plain End Steel Tubes Suitable for Welding or for Screwing to BS 21 Pipe Threads

Classification	Nominal Size	Outside Diameter		Wall Thickness	Mass of Black Tube	
	(mm)	Min.(mm)	Max.(mm)	(mm)	Plain End (kg/m)	Screw and Socket (kg/m)
MEDIUM	15	21.1	21.7	2.6	1.21	1.22
	20	26.6	27.2	2.6	1.56	1.57
	25	33.4	34.2	3.2	2.41	2.43
	32	42.1	42.9	3.2	3.1	3.13
	40	48.0	48.8	3.2	3.57	3.61
	50	59.8	60.8	3.6	5.03	5.1
	65	75.4	76.6	3.6	6.43	6.55
	80	88.1	89.5	4	8.37	8.54
	100	113.3	114.9	4.5	12.2	12.5
	125	138.7	140.6	5	16.6	17.1
	150	164.1	166.1	5	19.7	20.3
HEAVY	15	21.1	21.7	3.2	1.44	1.45
	20	26.6	27.2	3.2	1.87	1.88
	25	33.4	34.2	4	2.94	2.96
	32	42.1	42.9	4	3.8	3.83
	40	48.0	48.8	4	4.38	4.42
	50	59.8	60.8	4.5	6.19	6.26
	65	75.4	76.6	4.5	7.93	8.05
	80	88.1	89.8	5	10.3	10.5
	100	113.3	114.9	5.4	14.5	14.8
	125	138.7	140.6	5.4	17.9	18.4
	150	164.1	166.1	5.4	21.3	21.9

Note: Wall thickness tolerance is -10%
Length tolerance is +20mm/0

EN 10255 Non-alloy Steel Tubes Suitable for Welding and Threading

Classification	Nominal Size	Outside Diameter		Wall Thickness	Mass of Black Tube		
	(mm)	Min.(mm)	Max.(mm)	(mm)	Plain End (kg/m)	Screw and Socket (kg/m)	
MEDIUM	15	21.1	21.7	2.6	1.21	1.22	
	20	26.6	27.2	2.6	1.56	1.57	
	25	33.4	34.2	3.2	2.41	2.43	
	32	42.1	42.9	3.2	3.1	3.13	
	40	48.0	48.8	3.2	3.57	3.61	
	50	59.8	60.8	3.6	5.03	5.1	
	65	75.4	76.6	3.6	6.43	6.55	
	80	88.1	89.5	4	8.37	8.54	
	100	113.3	114.9	4.5	12.2	12.5	
	125	138.7	140.6	5	16.6	17.1	
	150	164.1	166.1	5	19.7	20.3	
	HEAVY	15	21.1	21.7	3.2	1.44	1.45
		20	26.6	27.2	3.2	1.87	1.88
		25	33.4	34.2	4	2.94	2.96
32		42.1	42.9	4	3.8	3.83	
40		48.0	48.8	4	4.38	4.42	
50		59.8	60.8	4.5	6.19	6.26	
65		75.4	76.6	4.5	7.93	8.05	
80		88.1	89.8	5	10.3	10.5	
100		113.3	114.9	5.4	14.5	14.8	
125		138.7	140.6	5.4	17.9	18.4	
150		164.1	166.1	5.4	21.3	21.9	

Note: Wall thickness tolerance is -10%
Length tolerance is +20mm/0

Specifications of Welded Steel Pipe

AS 1074 Steel Tubes and Tubulars for Ordinary Service

Classification	Nominal Size	Outside Diameter		Wall Thickness	Mass of Black Tube	
	(mm)	Min.(mm)	Max.(mm)	(mm)	Plain End (kg/m)	Screw and Socket (kg/m)
MEDIUM	15	21.1	21.7	2.6	1.21	1.22
	20	26.6	27.2	2.6	1.56	1.57
	25	33.4	34.2	3.2	2.41	2.43
	32	42.1	42.9	3.2	3.1	3.13
	40	48.0	48.8	3.2	3.57	3.61
	50	59.8	60.8	3.6	5.03	5.1
	65	75.4	76.6	3.6	6.43	6.55
	80	88.1	89.5	4	8.37	8.54
	100	113.3	114.9	4.5	12.2	12.5
	125	138.7	140.6	5	16.6	17.1
HEAVY	15	21.1	21.7	3.2	1.44	1.45
	20	26.6	27.2	3.2	1.87	1.88
	25	33.4	34.2	4	2.94	2.96
	32	42.1	42.9	4	3.8	3.83
	40	48.0	48.8	4	4.38	4.42
	50	59.8	60.8	4.5	6.19	6.26
	65	75.4	76.6	4.5	7.93	8.05
	80	88.1	89.8	5	10.3	10.5
	100	113.3	114.9	5.4	14.5	14.8
	125	138.7	140.6	5.4	17.9	18.4
	150	164.1	166.1	5.4	21.3	21.9

Note: Wall thickness tolerance is -10% Length tolerance is +20mm/0

GB/T 3091-2015

Nominal Size	Outside Diameter	Wall Thickness		
		A (mm)	B (mm)	C (mm)
15	21.3	2.2	2.5	2.8
20	26.9	2.2	2.5	2.8
25	33.7	2.5	3.0	3.2
32	42.4	2.75	3.25	3.5
40	48.3	3.0	3.25	3.5
50	60.3	3.0	3.6	3.8
65	76.1	3.25	3.6	4.0
80	88.9	3.25	3.6	4.0
100	114.3	3.25	3.6	4.0
125	139.7	3.25	3.6	4.0
150	165.1	3.5	4.0	4.5
200	219.1	4.5	4.75	4.5

Welded Steel Pipe



Raw Material: Hot Rolled Coil
 Forming Method: F-F-X
 Welding Method: High-frequency Resistance Welding
 Size: 1/2" ---8"
 Temperature: -30°C--80°C
 Normal Pressure: 0.1 Mpa--8Mpa
 Connection: Grooved, Threaded, Beveled, Plain
 Application: Water System, Sprinkler System, Gas system, Oil and HAVC System
 Product Advantages:
 Advanced F-F-X forming technics, enhance the controllability.
 Thermatool solid state high frequency welding Machine, make sure the welding stability.
 On line Heat Treatment, make sure the seam hardness
 100% on line Eddy Current Testing and Hydrostatic Testing, make sure the welding quality.

Painted Steel Pipe



Coating Material: Anti-rust Paint, Primer Paint, Epoxy Paint
 Coating Color: Red, Black, Gray, Varnish
 Coating Thickness: 30um
 Coating Method: Painted Outside
 Size: 1" ---8"
 Temperature: -30°C--80°C
 Normal Pressure: 0.1 Mpa--8Mpa
 Connection: Grooved, Threaded, Plain
 Application: Sprinkler System, Gas system
 Product Advantages:
 Paint is high quality and environmental, meet the requirement of usage
 Coating is uniformity and smooth.
 Coating with good adhesion and hardness
 Coating with good anticorrosion, prolong the pipe life span.

Galvanized Steel Pipe

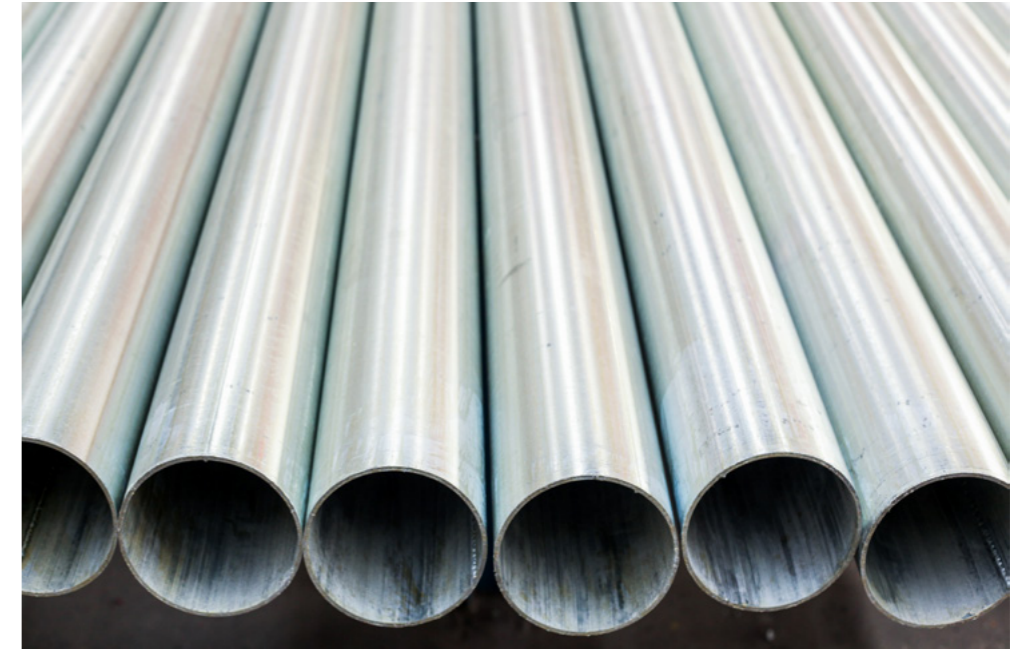

Galv.: Hot-dip Galvanizing
 Size: 1/2" ---8"
 Temperature: -30°C--80°C
 Normal Pressure: 0.1 Mpa--8Mpa
 Connection: Grooved, Threaded, Beveled, Plain
 Application: Water System, Sprinkler System, Gas system, Oil and HAVC System
 Product Advantages:
 Galv. coating is uniformity, clean and bright.
 Using 0# zinc ingot, with good anti-corrosion ability.

Epoxy Steel Pipe



Coating Material: Epoxy Resin Powder
 Coating Color: Red, Blue
 Coating Thickness: 40um-300um
 Size: 1/2" ---8"
 Temperature: -30°C--80°C
 Normal Pressure: 0.1 Mpa--5Mpa
 Connection: Grooved, Threaded, Plain
 Application: Water System, HAVC System
 Product Advantages:
 Epoxy powder is high-quality and environmental
 Coating with good anti-corrosion
 Coating with good hygienism
 Small resistance

Plastic-lining Steel Pipe

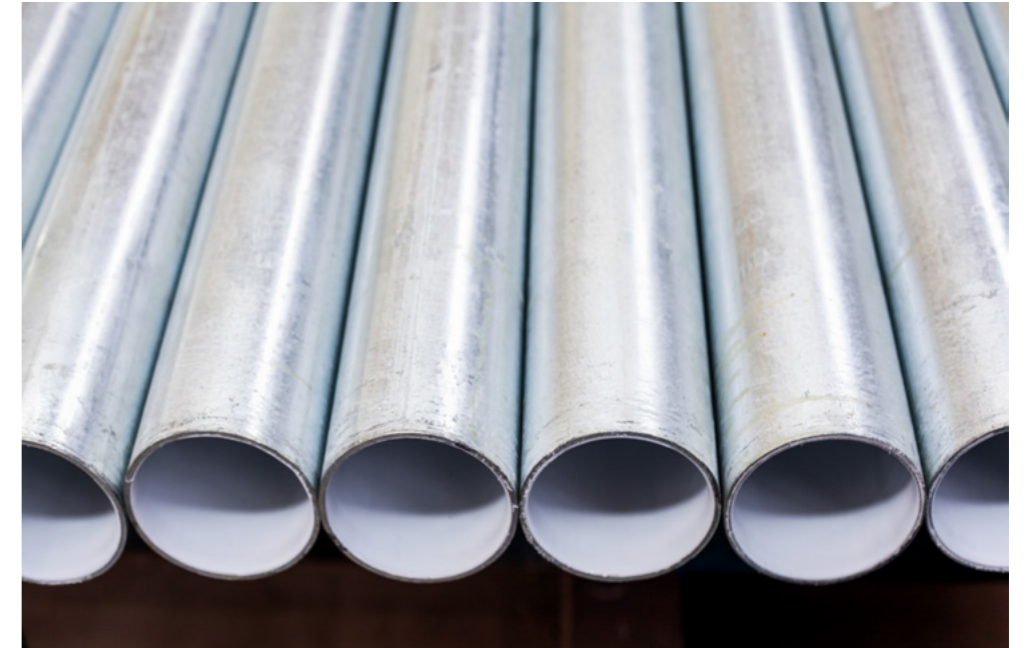

Raw Material: PE, Hot-dip Galv, Pipe
 Size: 1" ---8"
 Temperature: -30°C--80°C
 Normal Pressure: 0.1 Mpa--5Mpa
 Connection: Grooved, Threaded, Welded
 Application: Water System, Sprinkler System, Gas system, Oil and HAVC System
 Product Advantage:
 Outside is Galv. pipe, with good anti-corrosion, and not easy to distortion.
 Inside is PE pipe, environmental and health, inside surface is smooth.
 Ensure the quality i of inside fluid, Improve transport efficiency.

Brass Pipe Nipple



Material : ASTM B43
 Dimensions : ASTM B687
 Threads : ASME B1.20.1, ISO 7/1
 Schedule : Standard/Extra Heavy

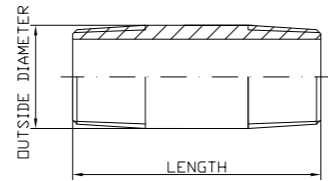

Brass Pipe Nipple Standard/Extra Heavy																		
Pipe Size	Pipe O.D.	Length Close	Pipe Nipple Lengths (In)															
			In	In	In													
1/8	0.405	3/4	11/2	2	2 1/2	3	3 1/2	4	4 1/2	5	5 1/2	6	7	8	9	10	11	12
1/4	0.540	7/8	11/2	2	2 1/2	3	3 1/2	4	4 1/2	5	5 1/2	6	7	8	9	10	11	12
3/8	0.675	1	11/2	2	2 1/2	3	3 1/2	4	4 1/2	5	5 1/2	6	7	8	9	10	11	12
1/2	0.840	1 1/8	11/2	2	2 1/2	3	3 1/2	4	4 1/2	5	5 1/2	6	7	8	9	10	11	12
3/4	1.050	1 3/8	11/2	2	2 1/2	3	3 1/2	4	4 1/2	5	5 1/2	6	7	8	9	10	11	12
1	1.315	1 1/2	11/2	2	2 1/2	3	3 1/2	4	4 1/2	5	5 1/2	6	7	8	9	10	11	12
1-1/4	1.660	1 5/8	X	2	2 1/2	3	3 1/2	4	4 1/2	5	5 1/2	6	7	8	9	10	11	12
1-1/2	1.900	1 3/4	X	2	2 1/2	3	3 1/2	4	4 1/2	5	5 1/2	6	7	8	9	10	11	12
2	2.375	2	X	2	2 1/2	3	3 1/2	4	4 1/2	5	5 1/2	6	7	8	9	10	11	12
2-1/2	2.875	2 1/2	X	X	2 1/2	3	3 1/2	4	4 1/2	5	5 1/2	6	7	8	9	10	11	12
3	3.500	2 5/8	X	X	X	3	3 1/2	4	4 1/2	5	5 1/2	6	7	8	9	10	11	12
4	4.500	2 7/8	X	X	X	3	3 1/2	4	4 1/2	5	5 1/2	6	7	8	9	10	11	12
5	5.562	3	X	X	X	3	3 1/2	4	4 1/2	5	5 1/2	6	7	8	9	10	11	12
6	6.625	3 1/8	X	X	X	X	3 1/2	4	4 1/2	5	5 1/2	6	7	8	9	10	11	12
8	8.625	3 1/2	X	X	X	X	3 1/2	4	4 1/2	5	5 1/2	6	7	8	9	10	11	12

Noted: Other lengths and size available. Contact us for details.

Steel Pipe Nipple with American Standard



Material : ASTM A53/A106/A333
 Dimensions : ASTM A733
 Threads : ASME B1.20.1
 Schedule : 40/80/160/XXS

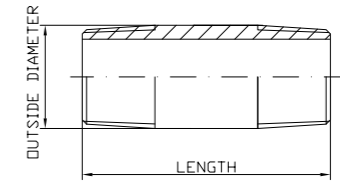

Carbon Steel Pipe Nipple Sch.40/80/160/XXS, Welded/Seamless																		
Pipe Size	Pipe O.D.	Length Close	Pipe Nipple Lengths (In)															
			In	In	In													
1/8	0.405	3/4	11/2	2	2 1/2	3	3 1/2	4	4 1/2	5	5 1/2	6	7	8	9	10	11	12
1/4	0.540	7/8	11/2	2	2 1/2	3	3 1/2	4	4 1/2	5	5 1/2	6	7	8	9	10	11	12
3/8	0.675	1	11/2	2	2 1/2	3	3 1/2	4	4 1/2	5	5 1/2	6	7	8	9	10	11	12
1/2	0.840	1 1/8	11/2	2	2 1/2	3	3 1/2	4	4 1/2	5	5 1/2	6	7	8	9	10	11	12
3/4	1.050	1 3/8	11/2	2	2 1/2	3	3 1/2	4	4 1/2	5	5 1/2	6	7	8	9	10	11	12
1	1.315	1 1/2	11/2	2	2 1/2	3	3 1/2	4	4 1/2	5	5 1/2	6	7	8	9	10	11	12
1-1/4	1.660	1 5/8	X	2	2 1/2	3	3 1/2	4	4 1/2	5	5 1/2	6	7	8	9	10	11	12
1-1/2	1.900	1 3/4	X	2	2 1/2	3	3 1/2	4	4 1/2	5	5 1/2	6	7	8	9	10	11	12
2	2.375	2	X	2	2 1/2	3	3 1/2	4	4 1/2	5	5 1/2	6	7	8	9	10	11	12
2-1/2	2.875	2 1/2	X	X	2 1/2	3	3 1/2	4	4 1/2	5	5 1/2	6	7	8	9	10	11	12
3	3.500	2 5/8	X	X	X	3	3 1/2	4	4 1/2	5	5 1/2	6	7	8	9	10	11	12
4	4.500	2 7/8	X	X	X	3	3 1/2	4	4 1/2	5	5 1/2	6	7	8	9	10	11	12
5	5.563	3	X	X	X	3	3 1/2	4	4 1/2	5	5 1/2	6	7	8	9	10	11	12
6	6.625	3 1/8	X	X	X	X	3 1/2	4	4 1/2	5	5 1/2	6	7	8	9	10	11	12
8	8.625	3 1/2	X	X	X	X	3 1/2	4	4 1/2	5	5 1/2	6	7	8	9	10	11	12

Noted: Other lengths and size available. Grooved end, SQ end and Bevel end available. Contact us for details.

Steel Pipe Nipple with British/Din Standard



Material : BS EN 10241
 Dimensions : BS EN 10241
 Threads : ISO7/1
 Schedule : Medium/Heavy

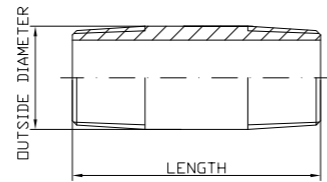

Carbon Steel Pipe Nipple Medium/Heavy ,Welded/Seamless																		
Pipe Size	Pipe O.D.	Length Close	Pipe Nipple Lengths (mm)															
mm	mm	mm																
6	10.3	19	30	40	50	60	80	100	120	150	180	200	250	300	350	400	450	500
8	13.7	27	30	40	50	60	80	100	4 1/2	150	180	200	250	300	350	400	450	500
10	17.1	28	30	40	50	60	80	100	4 1/2	150	180	200	250	300	350	400	450	500
15	21.3	37	X	40	50	60	80	100	4 1/2	150	180	200	250	300	350	400	450	500
20	26.7	39	X	40	50	60	80	100	4 1/2	150	180	200	250	300	350	400	450	500
25	33.4	46	X	X	50	60	80	100	4 1/2	150	180	200	250	300	350	400	450	500
32	42.2	51	X	X	50	60	80	100	4 1/2	150	180	200	250	300	350	400	450	500
40	48.3	51	X	X	50	60	80	100	4 1/2	150	180	200	250	300	350	400	450	500
50	60.3	60	X	X	X	60	80	100	4 1/2	150	180	200	250	300	350	400	450	500
65	76.1	69	X	X	X	X	80	100	4 1/2	150	180	200	250	300	350	400	450	500
80	88.9	75	X	X	X	X	80	100	4 1/2	150	180	200	250	300	350	400	450	500
100	114.3	87	X	X	X	X	X	100	4 1/2	150	180	200	250	300	350	400	450	500
125	141.3	96	X	X	X	X	X	X	120	150	180	200	250	300	350	400	450	500
150	168.3	96	X	X	X	X	X	X	120	150	180	200	250	300	350	400	450	500

Noted: Other lengths and size available. Grooved end, SQ end and Bevel end available. Contact us for details.

Stainless Steel Nipple with American Standard



Material : ASTM A312/A312M
 Dimensions : ASTM A733
 Threads : ASME B1.20.1
 Schedule : 40/80

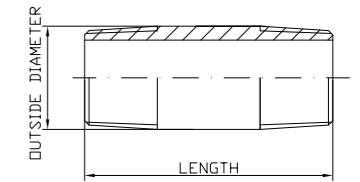

Stainless Steel Nipple Sch.40/80, Welded/Seamless																		
Pipe Size	Pipe O.D.	Length Close	Pipe Nipple Lengths (In)															
In	In	In																
1/8	0.405	3/4	1 1/2	2	2 1/2	3	3 1/2	4	4 1/2	5	5 1/2	6	7	8	9	10	11	12
1/4	0.540	7/8	1 1/2	2	2 1/2	3	3 1/2	4	4 1/2	5	5 1/2	6	7	8	9	10	11	12
3/8	0.675	1	1 1/2	2	2 1/2	3	3 1/2	4	4 1/2	5	5 1/2	6	7	8	9	10	11	12
1/2	0.840	1 1/8	1 1/2	2	2 1/2	3	3 1/2	4	4 1/2	5	5 1/2	6	7	8	9	10	11	12
3/4	1.050	1 3/8	1 1/2	2	2 1/2	3	3 1/2	4	4 1/2	5	5 1/2	6	7	8	9	10	11	12
1	1.315	1 1/2	1 1/2	2	2 1/2	3	3 1/2	4	4 1/2	5	5 1/2	6	7	8	9	10	11	12
1-1/4	1.660	1 5/8	X	2	2 1/2	3	3 1/2	4	4 1/2	5	5 1/2	6	7	8	9	10	11	12
1-1/2	1.900	1 3/4	X	2	2 1/2	3	3 1/2	4	4 1/2	5	5 1/2	6	7	8	9	10	11	12
2	2.375	2	X	2	2 1/2	3	3 1/2	4	4 1/2	5	5 1/2	6	7	8	9	10	11	12
2-1/2	2.875	2 1/2	X	X	2 1/2	3	3 1/2	4	4 1/2	5	5 1/2	6	7	8	9	10	11	12
3	3.500	2 5/8	X	X	X	3	3 1/2	4	4 1/2	5	5 1/2	6	7	8	9	10	11	12
4	4.500	2 7/8	X	X	X	3	3 1/2	4	4 1/2	5	5 1/2	6	7	8	9	10	11	12
5	5.563	3	X	X	X	3	3 1/2	4	4 1/2	5	5 1/2	6	7	8	9	10	11	12
6	6.625	3 1/8	X	X	X	X	3 1/2	4	4 1/2	5	5 1/2	6	7	8	9	10	11	12
8	8.625	3 1/2	X	X	X	X	3 1/2	4	4 1/2	5	5 1/2	6	7	8	9	10	11	12

Noted: Other lengths and size available. Grooved end, SQ end and Bevel end available. Contact us for details.

Steel Merchant Coupling with American Standard

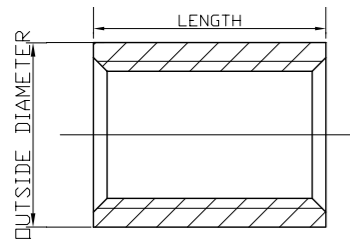

Material : ASTM A865
 Dimensions : ASTM A865
 Threads : ASME B1.20.1
 Schedule : Standard

Size	In	1/8	1/4	3/8	1/2	3/4	1	1 1/4	1 1/2	
Full	Pipe O.D.	In	0.563	0.719	0.875	1.063	1.313	1.576	1.900	2.200
	Length	In	3/4	1-1/8	1-1/8	1-1/2	1-9/16	1-15/16	2	2
Half	Pipe O.D.	In	0.563	0.719	0.875	1.063	1.313	1.576	1.900	2.200
	Length	In	0.335	0.531	0.531	0.709	0.748	0.925	0.965	0.965

Size	In	2	2 1/2	3	3 1/2	4	5	6	
Full	Pipe O.D.	In	2.75	3.250	4.000	4.625	5.000	6.296	7.390
	Length	In	2-1/16	3-1/16	3-3/16	3-5/16	3-7/16	3-11/16	3-15/16
Half	Pipe O.D.	In	2.75	3.250	4.000	4.625	5.000	6.296	7.390
	Length	In	1.051	1.496	1.555	1.634	1.673	1.811	1.949

Noted: Other lengths and size available, contact us for details

Steel Socket with British/Din Standard

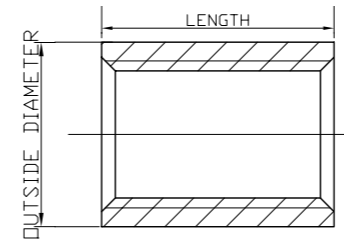

Material : BS EN 10241
 Dimensions : BS EN 10241
 Threads : ISO 7/1
 Schedule : Medium

Size	mm	6	8	10	15	20	25	32	
Standard	Pipe O.D.	mm	15	18.5	21.3	26.6	31.8	39.5	48.3
	Length	mm	17	25	26	34	36	43	48
Half	Pipe O.D.	mm	15	18.5	21.3	26.6	31.8	39.5	49
	Length	mm	8	11	12	16	19	21	25

Size	mm	40	50	65	80	100	125	150	
Standard	Pipe O.D.	mm	54.5	66.2	82	95	121.4	146.3	173.3
	Length	mm	48	56	65	71	83	92	92
Half	Pipe O.D.	mm	54.5	66.2	82	95	121.4	146.3	173.3
	Length	mm	22	26	30	34	40	44	44

Noted: Other lengths and size available, contact us for details

Steel Merchant Coupling with American Standard

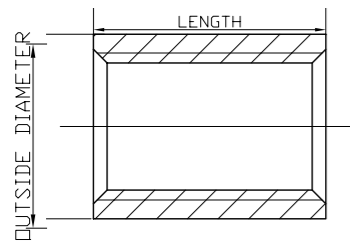

Material : ASTM A865
 Dimensions : ASTM A865
 Threads : ASME B1.20.1
 Schedule : Extra-Strong

Size	In	1/8	1/4	3/8	1/2	3/4	1	1 1/4	1 1/2	
Standard	Pipe O.D.	In	0.563	0.719	0.875	1.063	1.313	1.576	2.054	2.2
	Length	In	1-1/18	1-5/8	1-5/8	2-1/8	2-1/8	2-5/8	2-3/4	2-3/4

Size	In	2	2 1/2	3	3 1/2	4	5	6	
Standard	Pipe O.D.	In	2.875	3.375	4.0	4.625	5.2	6.296	7.39
	Length	In	2-7/8	4-1/8	4-1/4	4-3/8	4-1/2	4-5/8	4-7/8

Noted: Other lengths and size available, contact us for details

Steel Socket with British/Din Standard

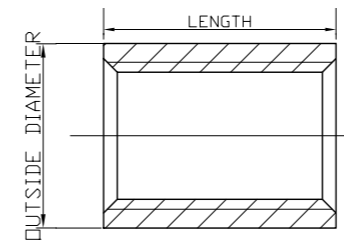

Material : BS EN 10241
 Dimensions : BS EN 10241
 Threads : ISO 7/1
 Schedule : Heavy

Size	mm	6	8	10	15	20	25	32	
Standard	Pipe O.D.	mm	15.0	18.5	22	27	32.5	39.5	49
	Length	mm	19.0	27.0	28.0	37.0	39.0	46.0	51.0

Size	mm	40	50	65	80	100	125	150	
Standard	Pipe O.D.	mm	56	68	84	98	124	151	177
	Length	mm	51.0	60.0	69.0	75.0	87.0	96.0	96.0

Noted: Other lengths and size available, contact us for details

Steel Nipple-Tank Type

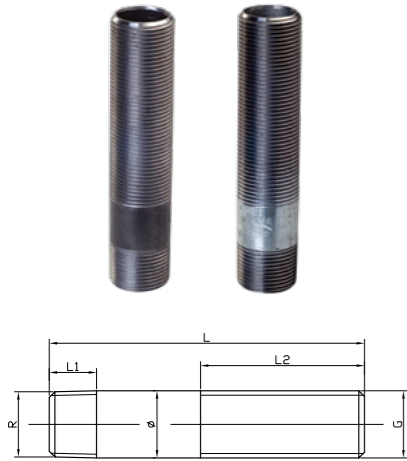

Size	L+2(mm)	L1 (mm)	L2(mm)	Ø (mm)	R	G
1/2X100X52MM	100	15	52	21.3	R1/2	G1/2
3/4X100X54MM	100	15	54	26.7	R3/4	G3/4
1X100X62MM	100	17	62	33.4	R1	G1
1 1/4X150X70MM	150	20	70	42.2	R1 1/4	G1 1/4
1 1/2X150X71MM	150	20	71	48.3	R1 1/2	G1 1/2
2X150X82MM	150	23	82	60.3	R2	G2

Threaded Welded Outlet

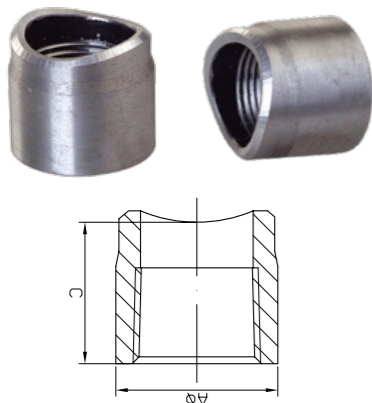

Material : ASTM A106
Threads : ASME B1.20.1, ISO 7/1

Size	In	1/2	3/4	1	1 1/4	1 1/2	2	2 1/2	3	4
Pipe Run Size	In	1 to 4	1 to 4	1 1/4 to 6	1 1/2 to 6	2 to 6	3 to 6	3 to 8	4 to 8	6 to 8
A	In	1.083	1.331	1.555	1.870	2.165	2.724	3.209	3.957	4.961
C	In	1.063	1.126	1.248	1.374	1.626	1.752	2.217	2.500	3.000

Grooved Welded Outlet

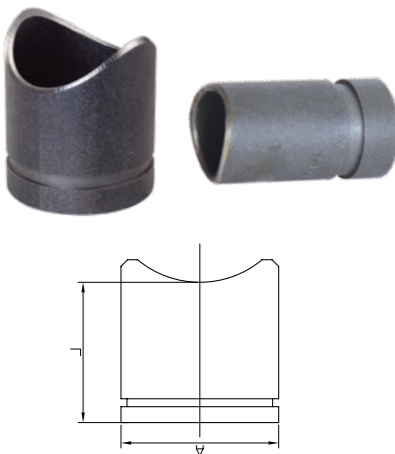

Material : ASTM A53
Groove : AWWA C606 and ISO 6182-12

Size	In	1 1/4	1 1/2	2	2 1/2	3	4	6	8
Pipe Run Size	In	1 1/4-8	1 1/2-8	2-8	2 1/2-8	3-8	4-8	6-8	8
A	In	1.660	1.900	2.375	2.875	3.500	4.500	6.625	8.625
L	In	2.969	2.969	2.969	2.969	2.969	3.976	3.976	4

Steel Dielectric Nipple

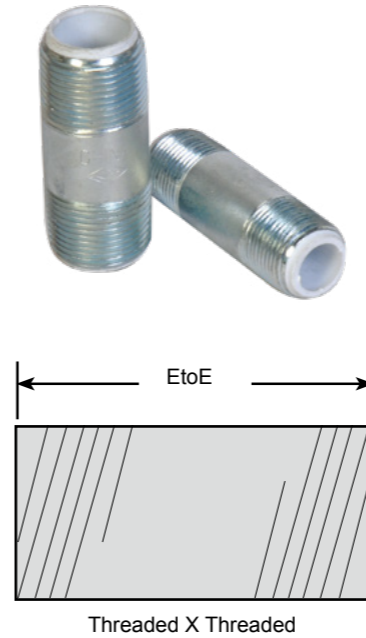

Nominal Dia. (inches)	Out.Dia. (inches)	Max. Work. Press. (PSI/kPa)	End to End (inches)	Aprx.Wgt.Each (Lbs./kg)
1/2	0.840	300 / 2065	2-1/2	0.15 / 0.07
1/2	0.840	300 / 2065	3	0.18 / 0.08
3/4	1.050	300 / 2065	2	0.15 / 0.07
3/4	1.050	300 / 2065	2-1/2	0.20 / 0.09
3/4	1.050	300 / 2065	3	0.24 / 0.11
3/4	1.050	300 / 2065	4	0.34 / 0.15
1	1.315	300 / 2065	2-1/2	0.27 / 0.12
1	1.315	300 / 2065	3	0.34 / 0.15
1	1.315	300 / 2065	4	0.48 / 0.22
1-1/4	1.660	300 / 2065	4	0.65 / 0.30
1-1/2	1.900	300 / 2065	4	0.78 / 0.36
2	2.375	300 / 2065	4	1.06 / 0.48
2-1/2	2.875	300 / 2065	6	2.47 / 1.12
3	3.500	300 / 2065	6	3.23 / 1.47
3-1/2	4.000	300 / 2065	6	3.90 / 1.77
4	4.500	300 / 2065	6	4.61 / 2.10

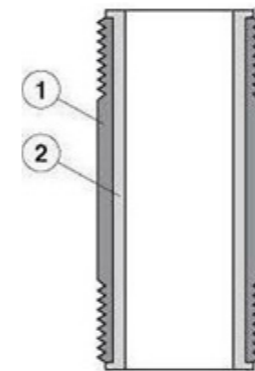

Material Specifications:

1. Body: Carbon steel pipe to ASTM A-53 type E, zinc electroplated.
2. Liner: Polypropylene (PP) plastic
 - Dimension: ASTM A733
 - Thread: ASME B1.20.1
 - Working Pressure: 300 psi
 - Temperature Range: 32°F to 230°F
 - For cool or heat water supply, good corrosion resistance in water. Plastic-lined steel nipples act as an insulator to prevent destructive electrolytic corrosion between dissimilar metals.
 - Crosslinked polyethylene (PEX) plastic, and polyethylene (PE) plastic available when ask.
 - Meets NSF / ANSI 372 lead free requirement

Insert Adapter

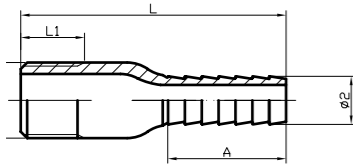

Size(In)	L±1.2(mm)	L1±1(mm)	Ø2±0.2	A±1
1/2	79	19.8	16.8	32.9
3/4	79	20	21.2	32.9
1	83.5	25	27.3	32.9
1 1/4	90	25.5	36.3	32.9
1 1/2	103.5	26	41.9	43.4
2	103.5	26.5	53	44.8
2 1/2	131	39.9	63.5	56(8 bar)
3	163	41.5	80	64(8 bar)
4	174	44	102.5	72(8 bar)
6	182	49.4	155	72(8 bar)

Features:

- Pipe: Carbon steel
- Thread: NPT / BSP
- Extra long barb is available upon request.
- Plated male adapter meets NSF / ANSI 372 lead free requirement.
- Plated steel for greater corrosion resistance than unplated steel, prevent rust and weathering.
- Common use: Cold water sprinkler, irrigation, and pump installation.
- Other sizes available, contact us for details.

Combination Nipple

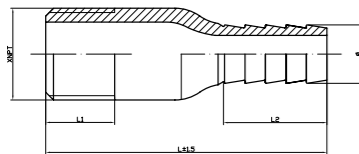

Size(In)	L±1.5(mm)	L1(mm)	L2(mm)	φ
1/2	79.5	17.5	35	13.5
3/4	81	17.5	35	19.8
1	89	20.5	35	26.2
1 1/4	95	21.5	43	32.5
1 1/2	112.5	22	51	38.6
2	124	22	51	51.3

Features:

- Pipe: Carbon steel
- Thread: NPT / BSP
- Barbed end to create a tight seal on a hose when used with a hose clamp or crimpsleeve, and male NPT / BSP thread on the other end to connection. connect to female NPT / BSP threaded.
- Plated steel for greater corrosion resistance than unplated steel, prevent rust and weathering.
- Recommended for low-pressure discharge or suction applications. Not for air service or steam service.
- The working pressure varies with the construction of the hose, and the application, shall not exceed the working pressure of the lowest rated component in the hose system.
- Other sizes available, contact us for details.

Insert Coupling

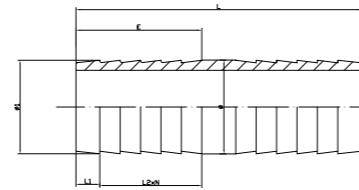

Size	L±1.5(mm)	φ	φ1±0.15	E±1(mm)	L1±0.1(mm)	L2±0.1(mm)	N
1/2X80	80	17	16.5	37	7	5	6
3/4X82	82	22	21.6	37	7	5	6
1X84	84	28	27.5	37	7	5	6
1 1/4X90	90	36.5	35.8	44	8	6	6
1 1/2X102	102	42.5	41.9	44	8	6	6
2X107	107	54.5	53.6	50	8	7	6

Features:

- Pipe: Carbon steel
- Plated male adapter meets NSF / ANSI 372 lead free requirement.
- Plated steel for greater corrosion resistance than unplated steel, prevent rust and weathering.
- Common use: Cold water sprinkler, irrigation, and pump installation.
- Other sizes available, contact us for details.

Hose Mender

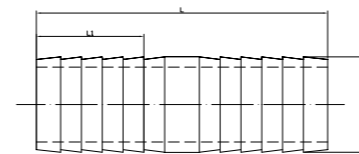

Size	L (mm)	L1 (mm)	φ1
1/2	89	35	13.5
3/4	89	35	19.8
1	89	35	26.2
1 1/4	108	43	32.5
1 1/2	118	51	38.6
2	123	51	51.3

Features:

- Material: Plated steel, unplated steel
- Type: Insert x Insert.
- Barbed end to create a tight seal on a hose when used with a hose clamp or crimpsleeve
- Plated steel for greater corrosion resistance than unplated steel, prevent rust and weathering.
- Recommended for low-pressure discharge or suction applications. Not for air service or steam service.
- The working pressure varies with the construction of the hose, and the application, shall not exceed the working pressure of the lowest rated component in the hose system.
- Other sizes available, contact us for details.

Hole Diameter of pipe

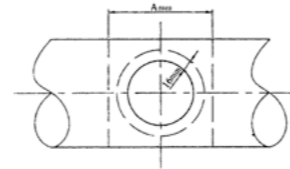

Hole-cutting Machine

Run Nominal Size mm/in	Outlet Nominal Size mm/in	Hole Dia. +3.2,0+0.13,0 mm/in	Run Nominal Size mm/in	Outlet Nominal Size mm/in	Hole Dia. +3.2,0+0.13,0 mm/in	Run Nominal Size mm/in	Outlet Nominal Size mm/in	Hole Dia. +3.2,0+0.13,0 mm/in
50 2"/60.3	15 1/2	38 1.50 A89	100 108.0 4"/114.3	15 1/2	38 1.50 A89	150 159.0 6"/168.3	15 1/2	38 1.50 A89
	20 3/4			20 3/4			20 3/4	
	25 1			25 1			25 1	
	32 1 1/4	45 1.75 A102		32 1 1/4	51 2.00 A102		32 1 1/4	
	40 1 1/2			40 1 1/2			40 1 1/2	
65 2 1/2" /73.0 76.1	15 1/2	38 1.50 A89	125 133.0 5"/141.3	50 2	64 2.50 A114	200 219.1 8 1/2"/219.1 250 10"/273.0	50 2	64 2.50 A114
	20 3/4			65 2 1/2"/76.1	70 2.75 A120		65 2 1/2"/76.1	70 2.75 A120
	25 1			80 3	89 3.50 A140		80 3	89 3.50 A140
	32 1 1/4	51 2.00 A102		15 1/2	38 1.50 A89		100 108.0/4	114 4.50 A165
	40 1 1/2			20 3/4			25 1	38 1.50 A89
80 3"/88.9	15 1/2	38 1.50 A89	125 133.0 5"/141.3	32 1 1/4	51 2.00 A102	200 219.1 8 1/2"/219.1 250 10"/273.0	32 1 1/4	51 2.00 A102
	20 3/4			40 1 1/2			50 2	
	25 1			50 2	64 2.50 A114		40 1 1/2	64 2.50 A114
	32 1 1/4	51 2.00 A102		65 2 1/2"/76.1	70 2.75 A120		50 2	64 2.50 A114
	40 1 1/2			80 3			89 3.50 A140	65 2 1/2"/76.1
50 2	64 2.50 A114	89 3.50 A140	80 3	80 3	89 3.50 A140	200 219.1 8 1/2"/219.1 250 10"/273.0	80 3	89 3.50 A140
				100 108.0/4	114 4.50 A165		100 108.0/4	114 4.50 A165

The outside surface of the pipe within 16mm from the hole must be clean and smooth.

Roll Groove Dimensions

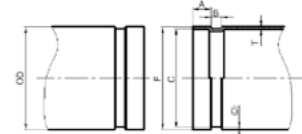

Roll Grooving Machine

Nominal Size mm/in	Pipe OD		Gasket seat A ±0.76±0.03 mm/in	Groove Width B ±0.76±0.03 mm/in	Groove Dia C		Groove Depth D(ref) mm/in	Max Allow Flare Dia F mm/in	Min. Allow wall thickness T mm/in
	Basic mm/in	Tolerance mm/in			Basic mm/in	Tolerance mm/in			
25 1	33.7 1.327	+0.41 -0.026	15.88 0.625	7.14 0.281	30.23 1.190	-0.38 -0.015	1.60 0.063	34.5 1.358	1.8 0.071
32 1 1/4	42.4 1.669	+0.50 -0.023	15.88 0.625	7.14 0.281	38.99 1.535	-0.38 -0.015	1.60 0.063	43.3 1.705	1.8 0.071
40 1 1/2	48.3 1.900	+0.44 -0.020	15.88 0.625	7.14 0.281	45.09 1.779	-0.38 -0.015	1.60 0.063	49.4 1.945	1.8 0.071
50 2	60.3 2.375	+0.61 -0.024	15.88 0.625	8.74 0.344	57.15 2.250	-0.38 -0.015	1.60 0.063	62.2 2.449	1.8 0.071
65 2 1/2	73.0 2.875	+0.74 -0.029	15.88 0.625	8.74 0.344	69.09 2.720	-0.46 -0.018	1.98 0.078	75.2 2.961	2.3 0.091
65 2 1/2	76.1 3.000	+0.76 -0.030	15.88 0.625	8.74 0.344	72.26 2.845	-0.46 -0.018	1.99 0.078	77.7 3.059	2.3 0.091
80 3	88.9 3.500	+0.89 -0.031	15.88 0.625	8.74 0.344	84.94 3.344	-0.46 -0.018	1.98 0.078	90.6 3.567	2.3 0.091
100 4	108.0 4.250	+1.07 -0.031	15.88 0.625	8.74 0.344	103.73 4.084	-0.51 -0.020	2.11 0.083	109.7 4.319	2.3 0.091
100 4	114.3 4.500	+1.14 -0.031	15.88 0.625	8.74 0.344	110.08 4.334	-0.51 -0.020	2.11 0.083	116.2 4.575	2.3 0.091
125 5	133.0 5.250	+1.32 -0.031	15.88 0.625	8.74 0.344	129.13 5.084	-0.51 -0.020	2.11 0.083	134.9 5.311	2.9 0.114
125 5	139.7 5.500	+1.40 -0.031	15.88 0.625	8.74 0.344	135.48 5.334	-0.51 -0.020	2.11 0.083	141.7 5.579	2.9 0.114
125 5	141.3 5.563	+1.42 -0.031	15.88 0.625	8.74 0.344	137.03 5.395	-0.56 -0.022	2.13 0.084	143.5 5.650	2.9 0.114
150 6	159.0 6.250	+1.60 -0.031	15.88 0.625	8.74 0.344	154.50 6.083	-0.56 -0.022	2.16 0.085	161.0 6.339	2.9 0.114
150 6	165.1 6.500	+1.60 -0.031	15.88 0.625	8.74 0.344	160.8 6.330	-0.56 -0.022	2.16 0.085	167.1 6.579	2.9 0.114
150 6	168.3 6.625	+1.60 -0.031	15.88 0.625	8.74 0.344	163.96 6.455	-0.56 -0.022	2.16 0.085	170.7 6.720	2.9 0.114
200A 8	216.3 8.516	+1.60 -0.031	19.05 0.750	11.91 0.469	211.60 8.331	-0.64 -0.025	2.35 0.093	219.8 8.653	2.9 0.114
200 8	219.1 8.625	+1.60 -0.031	19.05 0.750	11.91 0.469	214.40 8.441	-0.64 -0.025	2.34 0.092	221.5 8.720	2.9 0.114
250A 10	267.4 10.528	+1.60 -0.031	19.05 0.750	11.91 0.469	262.60 10.339	-0.69 -0.027	2.40 0.095	270.9 10.665	3.6 0.142
250 10	273.0 10.750	+1.60 -0.031	19.05 0.750	11.91 0.469	268.28 10.562	-0.69 -0.027	2.39 0.094	275.4 10.842	3.6 0.142
300A 12	318.5 12.539	+1.60 -0.031	19.05 0.750	11.91 0.469	312.90 12.319	-0.76 -0.030	2.77 0.109	322.0 12.677	4.0 0.158
300 12	323.9 12.750	+1.60 -0.031	19.05 0.750	11.91 0.469	318.29 12.531	-0.76 -0.030	2.77 0.109	326.2 12.842	4.0 0.158
350 14	377.0 14.842	+1.60 -0.031	23.83 0.938	11.91 0.469	371.44 14.623	-0.76 -0.030	2.77 0.109	379.5 14.941	4.5 0.177
400 16	426.0 16.772	+1.60 -0.031	23.83 0.938	11.91 0.469	420.46 16.553	-0.76 -0.030	2.77 0.109	428.5 16.870	4.5 0.177
500 20	529.0 20.827	+1.60 -0.031	25.40 1.000	11.91 0.469	523.46 20.608	-0.76 -0.030	2.77 0.109	533.0 20.984	5.0 0.197

Basic Dimension for American Standard Pipe Threads

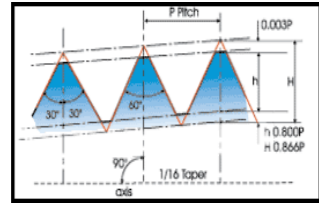

Taper thread
 $H = 0.866025 p = 0.866025/n$
 $h = 0.800 p = 0.800/n$

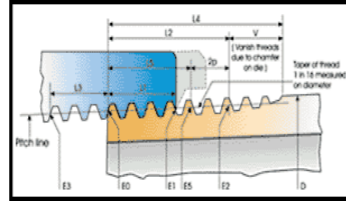

Parallel thread
 $L2 = (0.8D + 6.8) 1/n = (0.80D + 6.8)p$

Nominal Pipe Size (inches)	O.D. of Pipe (D)	Threads /in (N)	Pitch of Thread (P)	Pitch Dia. at Beginning of External Thread (E0)	Handtight Engagement		Effective Thread, External			Depth of Thread h	
					Length ² (L1)		Diam. ³ (E1)	Length ⁴ (L2)			Diam. (E2)
					Inch	Thread		Inch	Thread		
1/8	0.405	27.0	0.03704	0.36351	0.1615	4.36	0.37360	0.2639	7.12	0.38000	0.029
1/4	0.540	18.0	0.05556	0.47739	0.2278	4.10	0.49163	0.4018	7.23	0.50250	0.044
3/8	0.675	18.0	0.05556	0.61201	0.2400	4.32	0.62701	0.4078	7.34	0.63750	0.044
1/2	0.840	14.0	0.07143	0.75843	0.3200	4.48	0.77843	0.5337	7.47	0.79179	0.057
3/4	1.050	14.0	0.07143	0.96768	0.3390	4.75	0.98887	0.5457	7.64	1.00179	0.057
1	1.315	11.5	0.08696	1.21363	0.4000	4.60	1.23863	0.6826	7.85	1.25630	0.069
1 1/4	1.660	11.5	0.08696	1.55713	0.4200	4.83	1.58338	0.7068	8.13	1.60130	0.069
1 1/2	1.900	11.5	0.08696	1.79609	0.4200	4.83	1.82234	0.7235	8.32	1.84130	0.069
2	2.375	8.0	0.12500	2.26902	0.4360	5.01	2.29627	0.7565	8.70	2.31630	0.069
2 1/2	2.875	8.0	0.12500	2.71953	0.6820	5.46	2.76216	1.31375	9.10	2.79062	0.100
3	3.500	8.0	0.12500	3.34062	0.7660	6.13	3.38850	1.2000	9.60	3.41562	0.100
3 1/2	4.000	8.0	0.12500	3.83750	0.8210	6.57	3.88881	1.2500	10.00	3.91562	0.100
4	4.500	8.0	0.12500	4.33438	0.8440	6.75	4.38712	1.3000	10.40	4.41562	0.100
5	5.563	8.0	0.12500	5.39073	0.9370	7.50	5.44929	1.4063	11.25	5.47862	0.100
6	6.625	8.0	0.12500	6.44609	0.9580	7.66	6.50597	1.5125	12.10	6.54062	0.100

Nominal Pipe Size (inches)	Length, L1 Plane to L2 Plane External Thread (L2-L1)		Wrench Makeup Length for Internal Thread ⁷			Vanish Thread (V)		Overall ⁸ Length External Thread (L4)	Nominal Complete External Thread ⁵		Height of Thread (h)	Increase in Diam./Thread (0.0625/n)	Basic ⁶ Minor Diam. At Small End of Pipe (K0)
	Inch	Thread	Length (L3)		Diam. (E3)	Inch	Thread		Length (L5)	Diam. (E5)			
			Inch	Thread									
1/8	0.1024	2.76	0.1111	3	0.35656	0.1285	3.47	0.3924	0.1898	0.37537	0.02963	0.00231	0.3339
1/4	0.1740	3.13	0.1667	3	0.46697	0.1928	3.47	0.5946	0.2907	0.49556	0.04444	0.00347	0.4329
3/8	0.1678	3.02	0.1667	3	0.60160	0.1928	3.47	0.6006	0.2967	0.63056	0.04444	0.00347	0.5676
1/2	0.2137	2.99	0.2143	3	0.74504	0.2478	3.47	0.7815	0.3909	0.78286	0.05714	0.00446	0.7013
3/4	0.2067	2.89	0.2143	3	0.95429	0.2478	3.47	0.7935	0.4029	0.99286	0.05714	0.00446	0.9105
1	0.2828	3.25	0.2609	3	1.19733	0.3017	3.47	0.9845	0.5089	1.24543	0.06957	0.00543	1.1441
1 1/4	0.2868	3.30	0.2609	3	1.54083	0.3017	3.47	1.0085	0.5329	1.59043	0.06957	0.00543	1.4876
1 1/2	0.3035	3.49	0.2609	3	1.77978	0.3017	3.47	1.0252	0.5496	1.83043	0.06957	0.00543	1.7265
2	0.3205	3.69	0.2609	3	2.25272	0.3017	3.47	1.0582	0.5826	2.30543	0.06957	0.00543	2.1995
2 1/2	0.4555	3.64	0.2500	2	2.70391	0.4337	3.47	1.5712	0.8875	2.77500	0.10000	0.00781	2.6195
3	0.4340	3.47	0.2500	2	3.32500	0.4337	3.47	1.6337	0.9500	3.40000	0.10000	0.00781	3.2406
3 1/2	0.4290	3.43	0.2500	2	3.82188	0.4337	3.47	1.6837	1.0000	3.90000	0.10000	0.00781	3.7375
4	0.4560	3.65	0.2500	2	4.31875	0.4337	3.47	1.7337	1.0500	4.40000	0.10000	0.00781	4.2344
5	0.4693	3.75	0.2500	2	5.37511	0.4337	3.47	1.8400	1.1563	5.46300	0.10000	0.00781	5.2907
6	0.5545	4.44	0.2500	2	6.43047	0.4337	3.47	1.9462	1.2625	6.52500	0.10000	0.00781	6.3461

Note: This information is selected from the International Standard for Pipe Threads, ASME B1.20.1.

Basic Dimension for British and Din Standard Pipe Threads

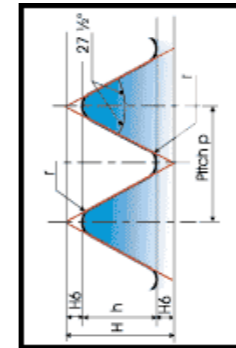
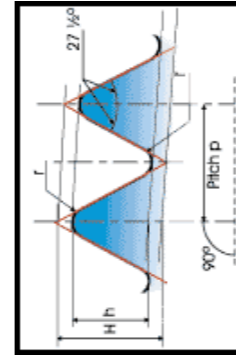
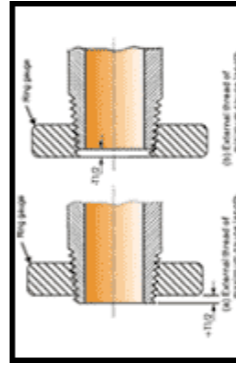

Fig 1 - Parallel thread
 $H = 0.960491 p$
 $h = 0.640327 p$
 $r = 0.137329 p$



Taper thread
 $H = 0.960237 p$
 $h = 0.640327 p$
 $r = 0.137278 p$



(a) External thread of maximum gauge length
 (b) External thread of minimum gauge length

International Standard ISO 7/1, Pipe Threads Dimensions

Designations of thread size	Number of threads in 25.4 mm	Pitch P	Height of thread h	Diameters at gauge plane			Gauge Length (external thread)			Tolerance on position of gauge			Length of useful external thread not less than		
				Major (gauge diameter) d	Pitch d2	Minor d1	Nominal	Tolerance ±T/2		Minimum	Tolerance ±T/2		For Nominal gauge length	For maximum gauge length	For minimum gauge length
								Turns of threads	Turns of threads						
1/8	28	0.907	0.581	9.728	9.147	8.566	4	0.9	1	1.1	1.1	6.5	7.4	5.6	
1/4	19	1.337	0.856	13.157	12.301	11.445	6	1.3	1	1.7	1.7	9.7	11	8.4	
3/8	19	1.337	0.856	16.662	15.806	14.95	6.4	1.3	1	1.7	1.7	10.1	11.4	8.8	
1/2	14	1.814	1.162	20.955	19.793	18.631	8.2	1.8	1	2.3	2.3	13.2	15	11.4	
3/4	14	1.814	1.162	26.441	25.279	24.117	9.5	1.8	1	2.3	2.3	14.5	16.3	12.7	
1	11	2.309	1.479	33.249	31.77	30.291	10.4	2.3	1	2.9	2.9	16.8	19.1	14.5	
1 1/4	11	2.309	1.479	41.91	40.431	38.952	12.7	2.3	1	2.9	2.9	19.1	21.4	16.8	
1 1/2	11	2.309	1.479	47.803	46.324	44.845	12.7	2.3	1	2.9	2.9	19.1	21.4	16.8	
2	11	2.309	1.479	59.614	58.135	56.656	15.9	2.3	1	2.9	2.9	23	25.7	21.1	
2 1/2	11	2.309	1.479	75.184	73.705	72.226	17.5	3.5	1	3.5	3.5	26.7	30.2	23.2	
3	11	2.309	1.479	87.884	86.405	84.926	20.6	3.5	1	3.5	3.5	29.8	33.3	26.3	
4	11	2.309	1.479	113.03	111.551	110.072	25.4	3.5	1	3.5	3.5	35.8	39.3	32.3	
5	11	2.309	1.479	138.43	136.951	135.472	28.6	3.5	1	3.5	3.5	40.1	43.6	36.6	
6	11	2.309	1.479	163.83	162.351	160.872	28.6	3.5	1	3.5	3.5	40.1	43.6	36.6	

Note: This information is selected from the International Standard ISO 7/1:2000: Pipe threads where pressure - tight joints, Table 1